



Digital Design : 2021-22

Lecture 12 : Hazards

By Dr. Sanjay Vidhyadharan

sanjayvidhyadharan.in

Hazard

- A hazard is a momentary unwanted switching transient at a logic function's output (Glitch).
- Hazards/glitches occur due to unequal propagation delays along different paths in a combinational circuit.
- We can take steps to try and eliminate hazards.
- There are two types of hazards; static and dynamic.

Static Hazard

Static-0 Hazard:

- Occurs when output is 0 and should remain at 0, but temporarily switches to a 1 due to a change in an input.

Static-1 Hazard:

- Occurs when output is 1 and should remain at 1, but temporarily switches to a 0 due to a change in an input.

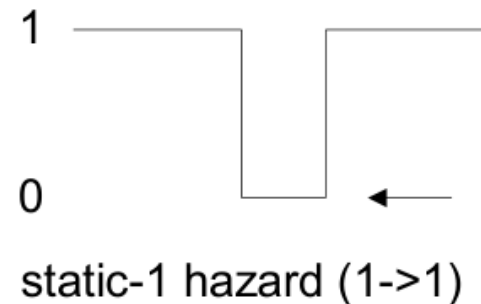
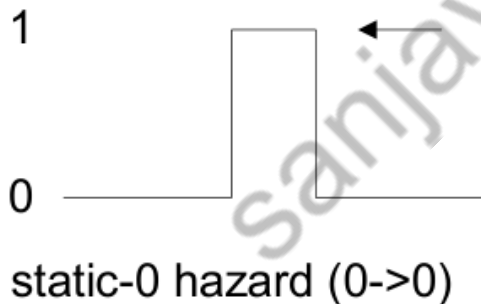

Dynamic Hazard

Dynamic Hazard:

- Occurs when an input changes, and a circuit output should change **0 -> 1** or **1 -> 0**, but temporarily flips between values.

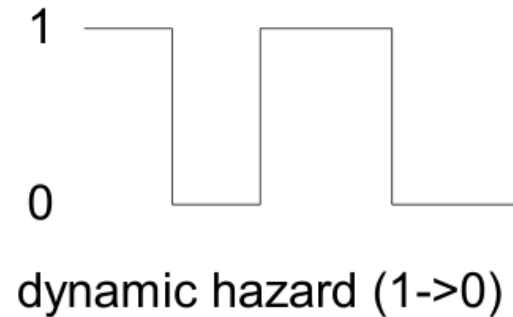
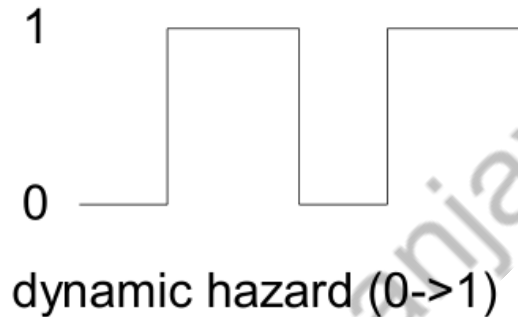

Static Glitch Example

Consider the following circuit with delays where only one input (input b) changes...

Draw a timing diagram to see what happens at output with delays.

From the logic expression, we see that b changing should result in the output remaining at logic level 1...

Due to delay, the output goes 1->0->1 and this is an output glitch; **we see a static-1 hazard.**

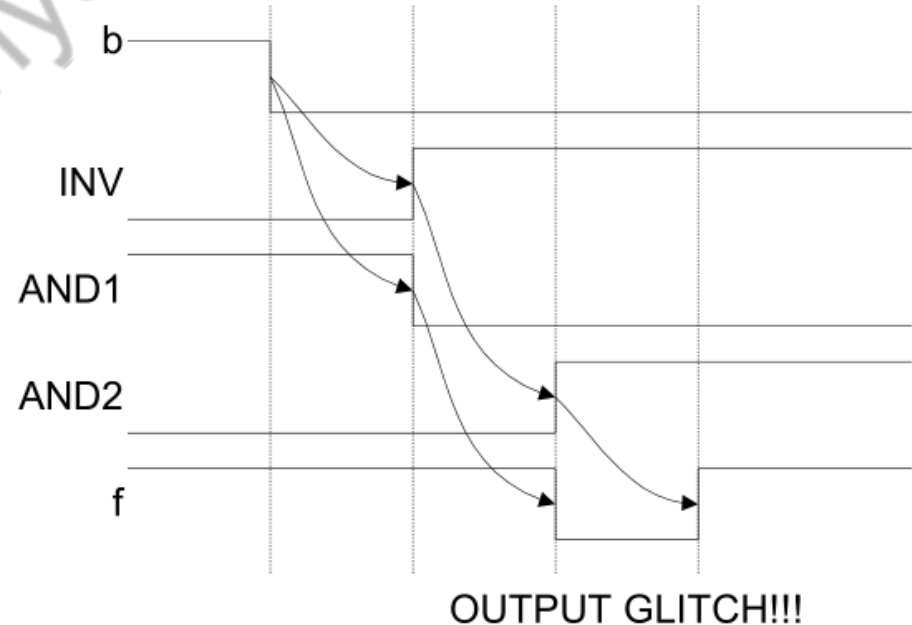
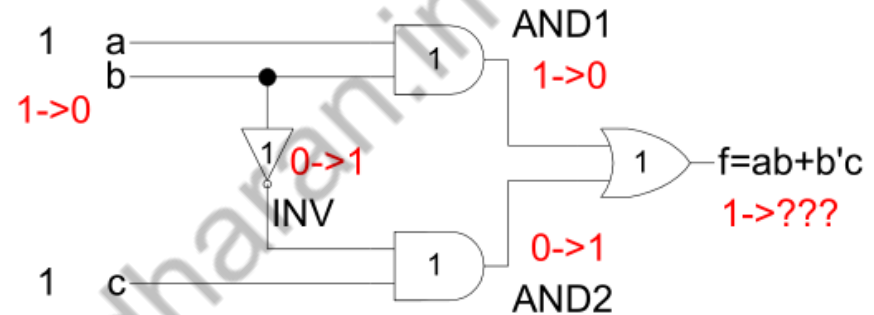

Static Glitch Elimination

When circuits are implemented as **2-level SOP (2-level POS)**, we can detect and remove hazards by inspecting the K-Map and **adding redundant product (sum) terms**.

	bc			
	00	01	11	10
a				
0	0	1	0	0
1	0	1	1	1

$$f=ab+b'c$$

Observe that when input b changes from $1 \rightarrow 0$ (as in the previous timing diagram), that we “jump” from one product term to another product term.

- ***If adjacent minterms are not covered by the same product term, then a HAZARD EXISTS!!!***

Static Glitch Elimination

	bc	00	01	11	10
a	0	0	1	0	0
1	0	1	1	1	

$$f = ab + b'c + ac$$

The extra product term does not include the changing input variable, and therefore serves to prevent possible momentary output glitches due to this variable.

Static Glitch Elimination

The redundant product term is not influenced by the changing input.

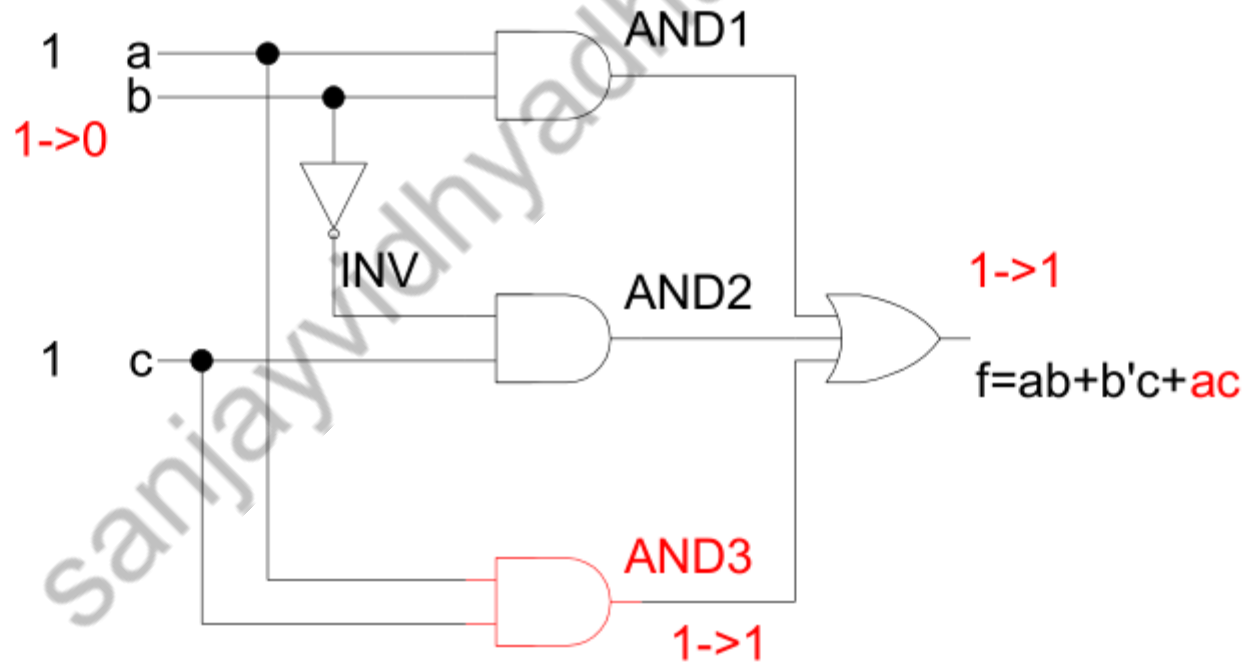

Thank you

sanjayvidhyadharan.in