



# **Digital Design**

## **First Semester 2020-21**

### **Tutorial : 11**

**Memory and PLD**

SanjayVidhyaAdharan.in

# Problem 1

**1. Realize the following logic functions with 8 X 4 PROMs.**

(i)  $F1 = AB + B'C$

(ii)  $F2 = (A+B'+C)(A'+B)$

(iii)  $F3 = A + BC$

# Solution

First, we convert each function to canonical SOP form.

$$\begin{aligned}f_1(A,B,C) &= A.B + B'.C = A.B.C' + A.B.C + A'.B'.C + A.B'.C \\ &= \Sigma m(1,5,6,7)\end{aligned}$$

$$\begin{aligned}f_2(A,B,C) &= (A+B'+C).(A'+B) \\ &= (A+B'+C).(A'+B+C').(A'+B+C) \\ &= \Pi M(2,4,5) = \Sigma m(0,1,3,6,7)\end{aligned}$$

$$\begin{aligned}f_3(A,B,C) &= A + B.C = A.B'.C' + A.B'.C + A.B.C' + A.B.C + A'.B.C \\ &= \Sigma m(3,4,5,6,7)\end{aligned}$$

# Solution

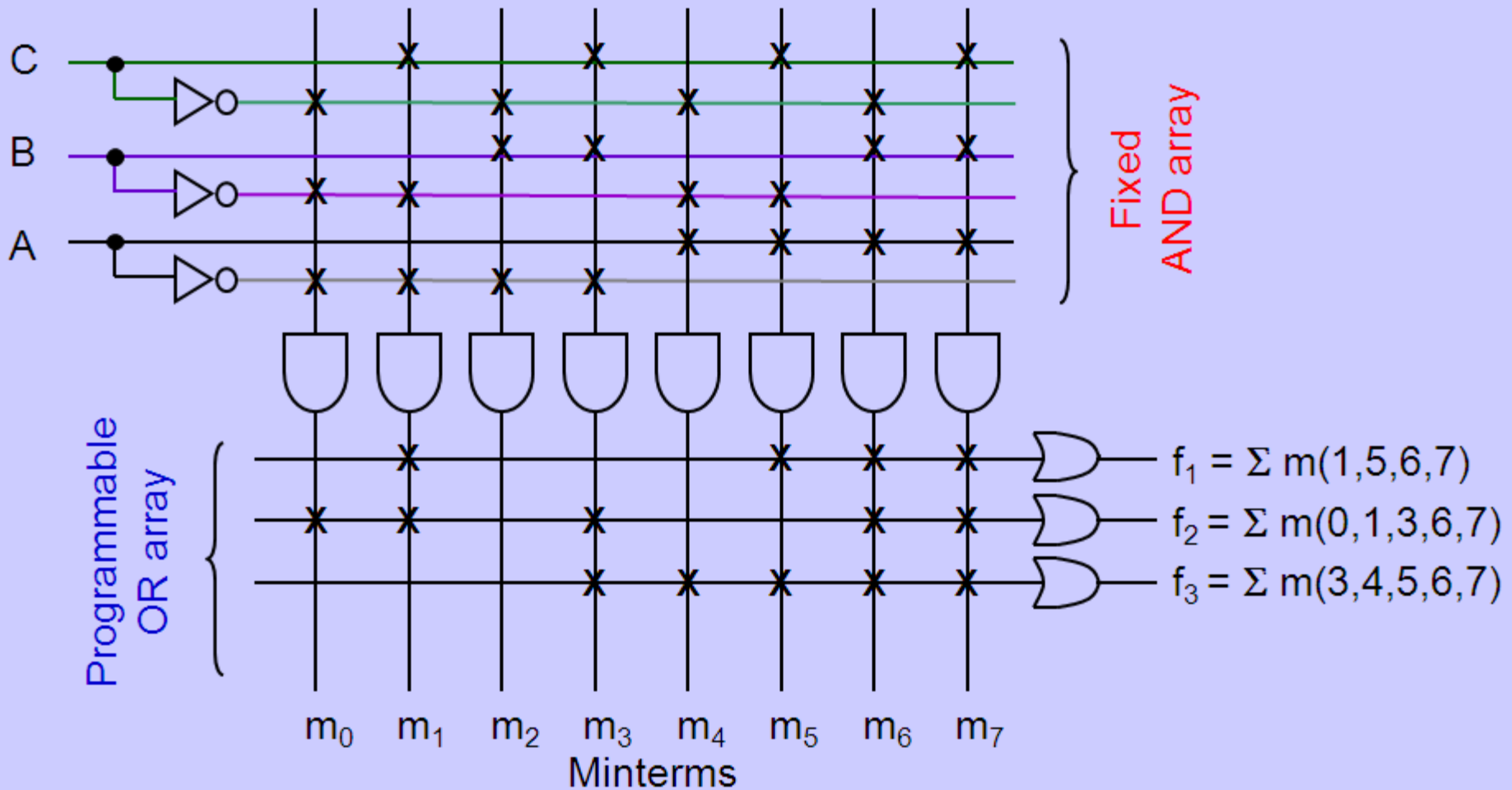

# Problem 2

A Boolean function is defined by the truth table

$A$	$B$	$C$	$F_1$	$F_2$
0	0	0	0	0
0	0	1	0	0
0	1	0	0	0
0	1	1	0	1
1	0	0	1	0
1	0	1	1	1
1	1	0	0	0
1	1	1	1	1

(a) Truth table

Implement the circuit with a PLA having three inputs, three product terms and two outputs

# Solution

- ◆ **Solution:**
- ◆ **Map simplification:**

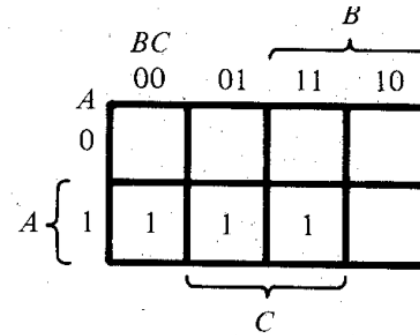

$$F_1 = AB' + AC$$

Product term	Inputs			Outputs	
	A	B	C	F <sub>1</sub>	F <sub>2</sub>
AB'	1	0	—	1	—
AC	1	—	1	1	1
BC	—	1	1	—	1
				T	T
					T/C

(c) PLA program table

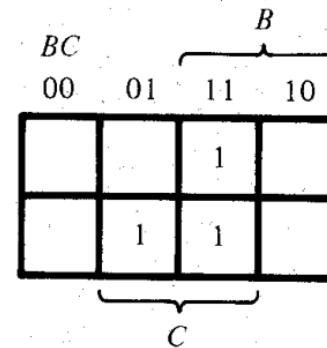

$$F_2 = AC + BC$$

(b) Map simplification

# Solution

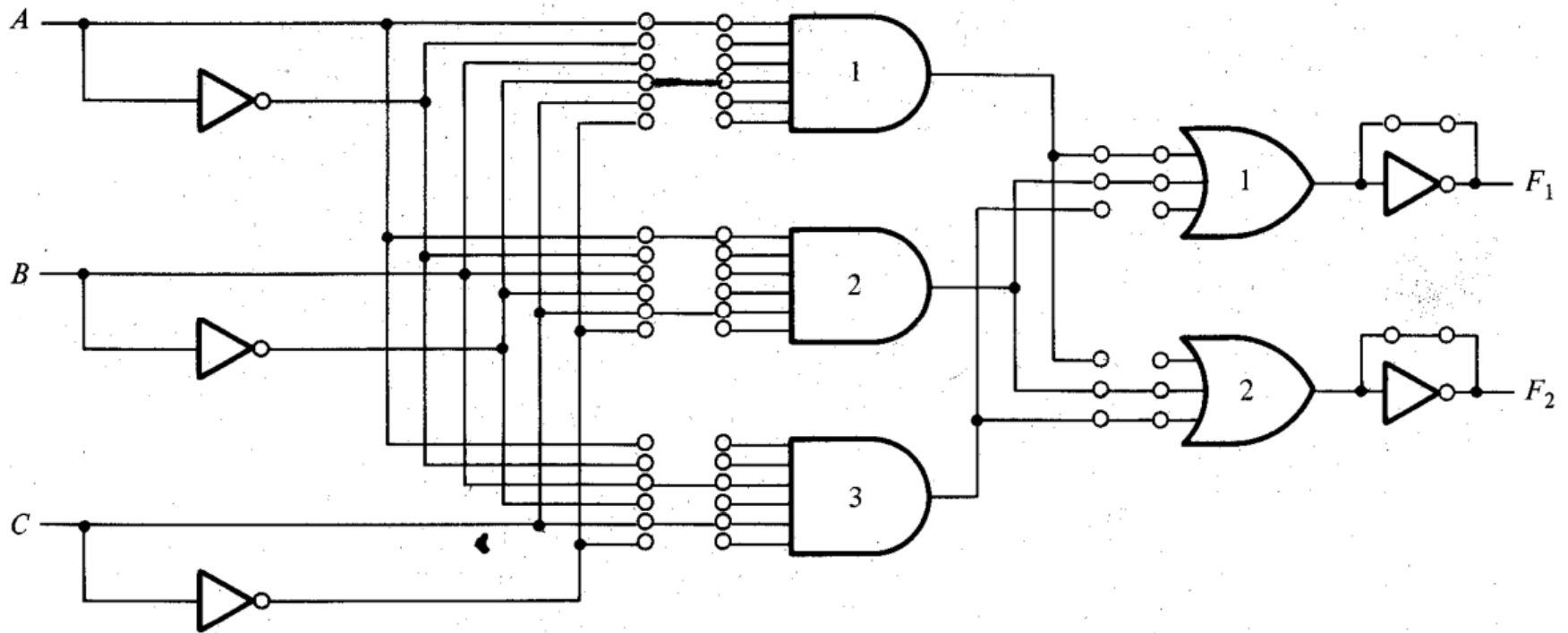

# Problem 3

Considering the following Boolean functions,  
design a combinational circuit using a PAL:

$$w(A, B, C, D) = \sum (2, 12, 13)$$

$$x(A, B, C, D) = \sum (7, 8, 9, 10, 11, 12, 13, 14, 15)$$

$$y(A, B, C, D) = \sum (0, 2, 3, 4, 5, 6, 7, 8, 10, 11, 15)$$

$$z(A, B, C, D) = \sum (1, 2, 8, 12, 13)$$



# Solution

- ◆ Simply the four functions to a minimum number of terms:

$$w = ABC' + A'B'CD'$$

$$x = A + BCD$$

$$y = A'B + CD + B'D'$$

$$z = ABC' + A'B'CD' + AC'D' + A'B'C'D$$

$$= w + AC'D' + A'B'C'D$$

# Solution

Product Term	AND Inputs					Outputs
	A	B	C	D	W	
1	1	1	0	-	-	$w = ABC' + A'B'CD'$
2	0	0	1	0	-	
3	-	-	-	-	-	
4	1	-	-	-	-	$x = A + BCD$
5	-	1	1	1	-	
6	-	-	-	-	-	
7	0	1	-	-	-	$y = A'B + CD + B'D'$
8	-	-	1	1	-	
9	-	0	-	0	-	
10	-	-	-	-	1	$z = w + AC'D' + A'B'C'D$
11	1	-	0	0	-	
12	0	0	0	1	-	

# Solution

