



Digital Design

First Semester 2020-21

Tutorial : 10

State Table Reduction

SanjayVidhyaadharan.in

Digital Design Tutorial : 10

1. A sequential circuit has one flip-flop Q, two inputs x and y, and one output S. It consists of a full-adder circuit connected to a D flip-flop, as shown. Derive the state table and state diagram of the sequential circuit.

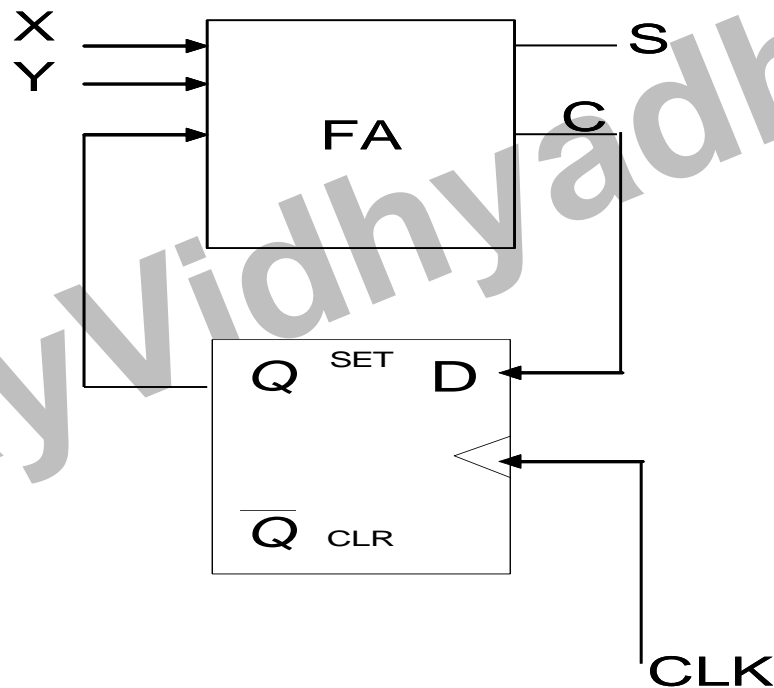

Digital Design Tutorial : 10

1. A sequential circuit has one flip-flop Q, two inputs x and y, and one output S. It consists of a full-adder circuit connected to a D flip-flop, as shown. Derive the state table and state diagram of the sequential circuit.

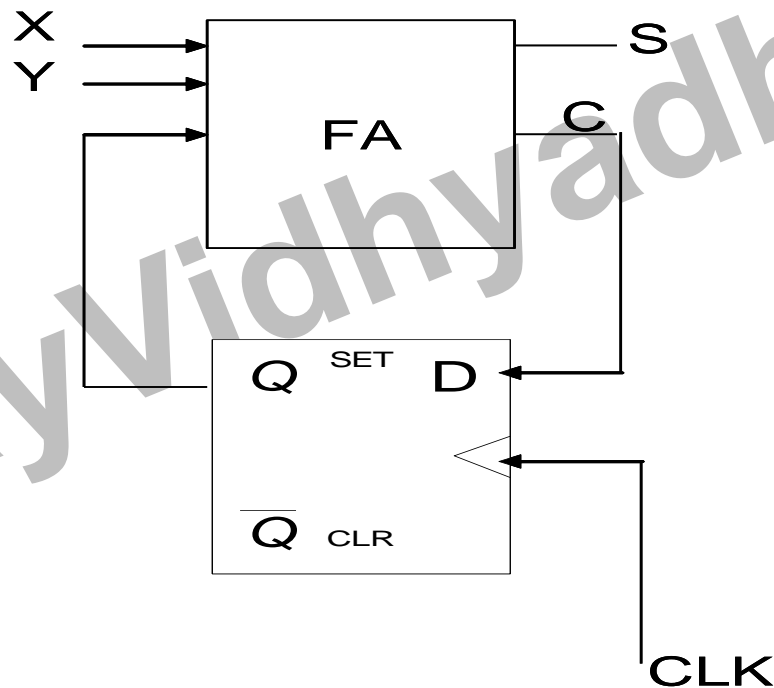

Digital Design Tutorial : 10

1.

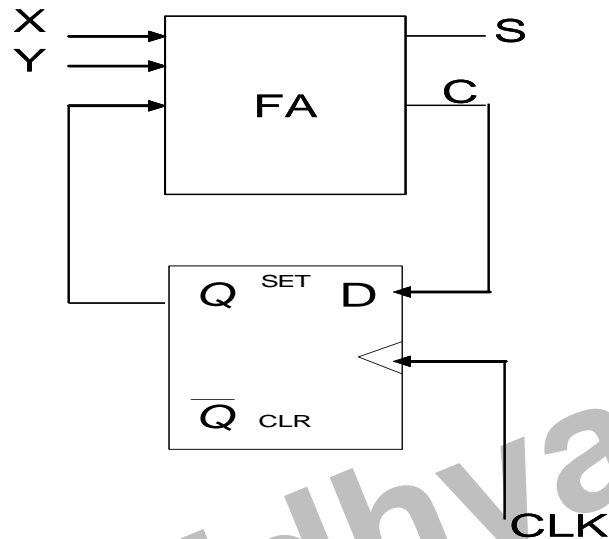

FA equations: $S = X \oplus Y \oplus Q$ $C = XY + XQ + YQ$

Input equation: $D_Q = C$
 $= XY + XQ + YQ$ (from the FA equations or from the K-map)

Characteristic equation:

$$Q(t+1) = D = XY + XQ + YQ$$

State equation:

$$Q(t+1) = C$$

Digital Design Tutorial : 10

State Table

1.

PRESENT STATE Q	INPUTS		NEXT STATE Q	OUTPUT S
	X	Y		
0	0	0	0	0
0	0	1	0	1
0	1	0	0	1
0	1	1	1	0
1	0	0	0	1
1	0	1	1	0
1	1	0	1	0
1	1	1	1	1

State Diagram:

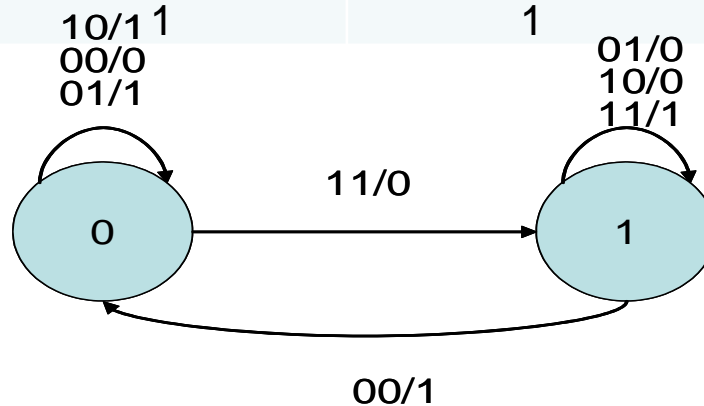

Digital Design Tutorial : 10

2. Reduce the number of states in the following table and tabulate the reduced state table.

PRESENT STATE	NEXT STATE		OUTPUT	
	X=0	X=1	X=0	X=1
a	f	b	0	0
b	d	c	0	0
c	f	e	0	0
d	g	a	1	0
e	d	c	0	0
f	f	b	1	1
g	g	h	0	1
h	g	a	1	0

Digital Design Tutorial : 10

2. Reduce the number of states in the following table and tabulate the reduced state table.

States b,e are the same ,we will replace state e with state b .

States d,h are the same ,we will replace state h with state d .

PRESENT STATE	NEXT STATE		OUTPUT	
	X=0	X=1	X=0	X=1
a	f	b	0	0
b	d	c	0	0
c	f	b	0	0
d	g	a	1	0
f	f	b	1	1
g	g	d	0	1

Digital Design Tutorial : 10

2. Reduce the number of states in the following table and tabulate the reduced state table.

States a,c are the same ,we will replace state c with state a .

PRESENT STATE	NEXT STATE		OUTPUT	
	X=0	X=1	X=0	X=1
a	f	b	0	0
b	d	a	0	0
d	g	a	1	0
f	f	b	1	1
g	g	d	0	1

Digital Design Tutorial : 10

3. Optimize using Implication Table .

State Table to be Reduced.

Present State	Next State		Output	
	x=0	x=1	x=0	x=1
a	d	a	0	0
b	e	a	0	0
c	g	f	0	1
d	a	d	1	0
e	a	d	1	0
f	c	b	0	0
g	a	e	1	0

Digital Design Tutorial : 10

3. Optimize using Implication Table .

State Table to be Reduced.

Present State	Next State		Output	
	x=0	x=1	x=0	x=1
a	d	a	0	0
b	e	a	0	0
c	g	f	0	1
d	a	d	1	0
e	a	d	1	0
f	c	b	0	0
g	a	e	1	0

b	(d,e) ✓					
c	x	x				
d	x	x	x			
e	x	x	x	✓		
f	(c,d) (a,b)	(c,e) (a,b)	x	x	x	
g	x	x	x	(d,e) ✓	(d,e) ✓	x
	a	b	c	d	e	f

Digital Design Tutorial : 10

3. Optimize using Implication Table .

b	(d,e) ✓					
c	x	x				
d	x	x	x			
e	x	x	x	✓		
f	(c,d) X (a,b)	(c,e) X (a,b)	x	x	x	
g	x	x	x	(d,e) ✓	(d,e) ✓	x
	a	b	c	d	e	f

Reduced State Table.

Present State	Next State		Output	
	x=0	x=1	x=0	x=1
a	d	a	0	0
c	d	f	0	1
d	a	d	1	0
f	c	a	0	0